



The Bourne Academy

Knowledge Organiser: KS4 – Design and Technology





Support with Exam content (Principles Paper)



1. Ergonomics and Anthropometrics.

Ergonomics

Ergonomics is the study of how people comfortably and effectively use products, the 'fit' between the users and products they use. An ergonomic design should make people more efficient at using it. An ergonomic mobile phone would be easy to hold, have buttons shaped to be comfortable and easy to press, its edges will be rounded, and the ear and mouth pieces will be at suitable distances from your ear and mouths.

It is about making things the correct size, shape and weight for humans. It's also about considering noise levels that products make and the impact this has on user comfort. It's about making sure products create temperatures that make working comfortable (No more than 20 degrees). It's making sure lamps and computer screens don't cause too much glare and make looking at them uncomfortable. It's also about making sure text and graphics are easy to read both in style and size.

Anthropometrics

Anthropometric Data is the data collected from humans that represents size. This data holds the size of all human body parts for a broad range of sizes, ages and for both genders. Designers use the average measurements to make sure their products fit the majority of consumers comfortably. Data consider 90 percent of the population. The smallest humans are considered to be in the 5th percentile, the largest in the 95th percentile, designers tend to use the 50th percentile data as it is the average.

2. Designing usable products.

Usability is the ease of use and learnability of a human-made object such as a tool or device. It is part of the broader term "user experience" and refers to the ease of access and/or use of a product together in the context of the user (what the user wants to do with it and the user's environment), determine its level of **usability**.

Inclusive design aims to remove the barriers that create effort and separation. It enables everyone to participate equally, confidently and independently in everyday activities. This does not mean you have to design for all seven billion people on Earth, but you should aim to exclude as few as possible.

3. Globalisation of Design and Manufacturing

Globalisation means increasing trade and manufacturing around the globe. Many companies sell products worldwide and develop an international influence. There are lots of reasons for companies to manufacture parts of their product in different countries.

Advantages: Materials may be cheaper abroad or more readily available.

Land for factories may be cheaper abroad. Labour costs are likely to be cheaper abroad. More people may be willing to complete factory floor jobs abroad. Products can be shipped and sold worldwide this can increase sales.

Disadvantages: Lower labour costs but is it ethically moral to pay someone less to do the job? Working conditions are often worse, safety issues etc. Factories often damage environments when being built. Extra costs for shipping products or parts back. It uses fuel and causes pollution.



4. Sustainability

It is important that products are made to last and have minimal impact on the environment. The word sustainability means 'to last', this applies to a product, materials, energy and the environment, we need to make sure we have enough materials and energy for future generations.

The 6 R's form the basis for companies doing this.

Reduce: Waste can be reduced by designing products that can be recycled locally, picking materials carefully for this purpose. Reducing plastics in packaging is important. You may have noticed how over recent years the use of plastics in packaging has been reduced, this is because it is easy to recycle cardboard. Reducing waste creates less landfill. Companies can reduce energy by only powering machines when they are needed or using renewable energy to power factories

Reuse: Reusing can involve designing refillable bottles and containers, using rechargeable energy sources to reuse batteries etc. Products that are designed to be reused multiple times are far less likely to be thrown into landfill and new products do not need to be made to replace them.

Recycle: Choosing recyclable materials and designing products so their materials can be reprocessed to make other products. Recycling materials is good because: It generates pride and environmental awareness, It saves natural resources, It conserves raw materials, Making products from recycled materials saves energy in most cases. Reduces the amount of materials dumped in landfills.

Repair: Design products that are repairable and can be fixed by the user. This means materials are less likely to be thrown away.

Rethink: Carry out a Life Cycle Assessment in order to identify how products or manufacturing methods can be made more environmentally friendly. By evaluating products and processes it allows these to be improved.

Refuse: Refuse to use certain materials or to buy certain products if they are not needed, reducing consumption, waste and use of raw materials. Refusing single use plastics will help reduce pollution and waste.



5. Energy Sources

Renewable Energy Sources

Solar – photovoltaic cells convert light to electricity.

Tidal – barrages are built across river estuary and turbines turn generators, electricity is generated.

Wave – motion of waves force air up a cylinder to turn turbines, electricity is generated.

Hydroelectric – dams trap water, the water is released and turns turbines, turbines turn generators and electricity is generated.

Biomass – fuel (sugar cane, wood etc) is burned to generate heat which heats water to make steam, the steam turns turbines which turn generators and distribute energy.

Wind – blades catch wind and turn turbines using gears, turbines turn generators and electricity is generated.

Non- Renewable Energy Sources

Coal and oil - Fuel is burnt to generate heat, which heats water to generate steam, steam turns turbines and they turn generators, electricity is generated.

Nuclear – nuclear fission generates heat, which heats water to generate steam, steam turns turbines and they turn generators, electricity is generated.

6. Circular/Linear Economy

Cradle to Cradle (Circular Economy)

A circular economy is an alternative to a traditional linear economy (make, use, dispose), in which we keep resources in use for as long as possible, extract the maximum value from them while they are in use, then recover and regenerate parts and materials at the end of their life. It stops as much landfill and pollution.

Cradle to Grave (Linear Economy)

A linear economy is where products and materials can not be reused or recycled. These products end up in land fill and pollute the environment.

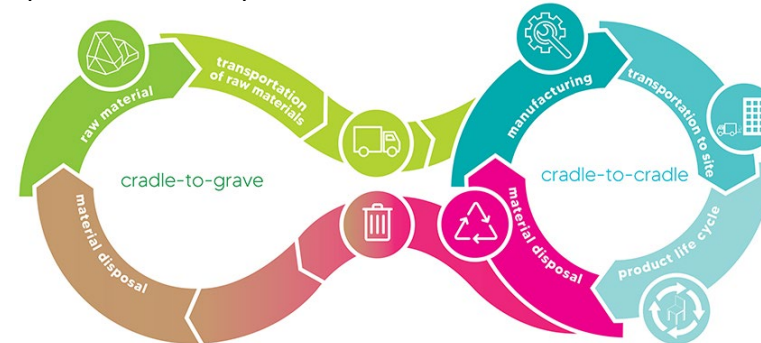

7. Fashion and Trends

Designers want product to be fashionable and appear modern and cool to its user. Failure to keep up with fashion and trends can mean a product will not sell well and will lead to commercial failure.

Trends tend to be dictated to by fashion designs and catwalk fashion. Fashion emerges from society and culture and is a representation of what people like at that specific time.

Fashion trends can include eco and sustainable design as well as follow trends with colours, materials and shape etc

These are influenced by seasons, popular culture and celebrity.



8. Obsolescence

This is when a product becomes obsolete. This means the point where it is no longer of any use.

Obsolescence is caused when a new product comes out that has better functions or is designed in a more modern way compared with its predecessor. A consumer simply chooses to stop using the old one and opts for a newer model. It can be the process of an object not working naturally or by being replaced with something better.

Technological Obsolescence is when new improved technology forces older models off the market and offers something that functions better, smarter and uses more modern technologies.

Planned Obsolescence

This is when companies plan for products to become Obsolete. One way of doing this is to change a products Aesthetic appearance to make a newer version look better, this way consumers will spend more money wanting the better version.

Companies can also plan ahead to include new versions of technologies in their products. This way, when a new version is released it will perform a better function than its predecessor. Washing machines and white goods are designed with planned obsolescence in mind meaning that the washing machine is designed to last a few years. Two or three years after purchase, the washing machine will only need minor inexpensive repairs. However, between 4 to 5 years the vital parts begin to wear out, the company won't provide replacements and a new machine will be needed.

Another example is a mobile phone. Mobile phones are often designed with only current technology in mind, despite the manufacturer's knowledge of future technological developments. For instance, a mobile phone may have connectors and chargers, that fit current products, such as head phones and computers. Eventually the 'old' USB / connections / jack plugs will be upgraded and make the product obsolete. The customer will need a new phone, even though their old phone still works. The old phone becomes obsolete.

Sometimes planned obsolescence can be a positive thing, products such as medical syringes and disposal razors can avoid spread of infections. While a partly disposable toothbrush is unavoidable, you can reduce 93 percent of toothbrush waste by replacing the head on these reusable toothbrush handles.



9. Aesthetics and colour theory

Colour can influence how people think, can provoke reactions and sway opinions. The use of colour in product design can manipulate the consumer you target and appeal to specific consumer groups. A basic example is the use of blue and pink for boys and girls, the use of red for danger and green for safety. In terms of electronic products, Green is commonly used for on and red is commonly used for off.

Colour harmony is the arrangement of colours to be aesthetically pleasing. Colour backgrounds can be used in product design to make certain features or text stand out, for example, red on white looks more dull than red on black.

Common meaning or association of colours:

Red	Aggressive, passion, strong and heavy, danger, socialism, heat
Blue	Comfort, loyalty, for boys, sea, sky, peace and tranquillity, cold
Yellow	Caution, spring and brightness, joy, cowardice, sunlight
Green	Money, health, jealousy, greed, food and nature
Brown	Nature, aged and eccentric, rustic, soil and earth, heaviness
Orange	Warmth, excitement and energy, religion, fire, gaudiness
Pink	Soft, healthy, childlike and feminine, gratitude, sympathy
Purple	Royalty, sophistication and religion, creativity, wisdom
Black	Dramatic, classy and serious, modern, evil, mourning
Grey	Business, cold and distinctive, humility, neutrality
White	Clean, pure and simple, innocence, elegance, peace

Aesthetics also is to do with proportion and symmetry, the size, form, texture and shape of a product can often affect if its perceived as beautiful (aesthetically pleasing).

Symmetry is often associated with beauty when designing. Symmetry creates balance, and balance in design in turn creates harmony, order and aesthetically pleasing results.

Symmetry is found everywhere in nature, and this is why we find it so beautiful. Symmetry can be reflective (a mirror image) or rotational (turned around a central axis).

Asymmetry is a break in symmetry, which, when used effectively, can make things more interesting from a design point of view.

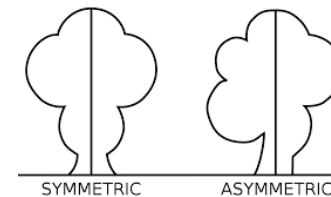



10. The impact of New Technologies

Designers and manufacturers have adapted and embraced new and emerging technologies in their designing and making activities. The last 40 years have seen a huge increase in the use of digital systems in design and technology, and new scientific technologies have led to advancements in materials that have changed the way in which products are produced.

Global Communication Systems

Digital information is now easily transferred through text, audio and visual format. This is done through the **internet, email and blue tooth.**

What are the benefits?

- Large documents can be easily transferred regardless of distance.
- The internet allows research to be carried out on trends and competitors easily.
- Marketing, Advertising and Sales is made easier and more accessible for customers.
- Improves the efficiency of offshore manufacturing.
- Saves time, packaging waste and lowers carbon footprint.

Cloud computing:

A network of online servers that store and manage data.

What are the benefits?

- Companies can access files at any location.
- Unlimited storage (Elastic resource).
- Files can be accessed from any location to edit.
- Files available instantly.
- Designers can more easily work remotely.
- Chance of damaged and lost data through physical server issues is reduced.
- Benefits globalisation and offshore manufacturing.

Automated manufacturing:

Manufacturing is made more accurate, fast and efficient.

Human workforces are being replaced by **robots, CAD, CAM, drones, sensors and automated production lines.**

What are the benefits?

- Less human error= less waste
- Quality is improved=improved business.
- Consistency of items are improved.
- Speed of production benefits profits
- More intricate products can be manufactured.
- Designs are easily edited and adjusted which improves the design process.
- Sensors are used to measure defects and alert quality issues on production runs.



10. The impact of New Technologies continued...

Additive Manufacturing:

Manufacturing that builds up 3D designs by slicing them up and building them in layers.

3D Printing takes a computer generated 3D image and splices it into layers.

It then using heated polymer (and other materials) to build up the design layer by layer. Creating an exact replica of the 3D Design.

What are the benefits?

- Quick production of prototypes means the design process/ iteration can be refined easily through testing.
- Fully functioning prototypes.
- A range of materials can be printed.
- Replaces human methods of modelling and prototyping which are slower and less accurate/ functioning. Saves time.
- Prototypes replicate designs with same level of accuracy and intricacy.
- Replacement components can be manufactured for efficiently.

Virtual Reality:

VR is being used to test concept ideas. It allows designers to practice product assembly before building production lines.

It allows designers to interact with concept ideas before prototyping.

What are the benefits?

- Computer simulations can test products without wasting prototypes and materials.
- Gives designers a more realistic feel for ideas and concepts.
- By visualising concepts in simulated scenarios time can be saved by predicting problems more accurately.
- Early feedback from consumers can be sought to improve products.

Internet of things:

Where electronic devices connect together without human interference.

These devices send and receive signals through sensors, bar codes and detection devices. They communicate via networks and the internet.

What are the benefits?

- Manufacturing production runs can detect errors and fix the problem.
- Production runs become more accurate with less waste.
- Warehouses can keep track of stock and usage to automatically place orders. This minimises waste.



10. The impact of New Technologies continued...

Computer Aided Design (CAD) and Computer Aided Manufacture (CAM)

CAD systems include	CAM systems include
Computer	CNC lathe, miller, router
Graphics tablet	Computerised embroidery
Scanner (flat and 3D)	Laser cutter
2D/3D software	3D printer
	Plotter/cutter, vinyl cutter

CAD	
ADVANTAGES	DISADVANTAGES
Ability to edit and make alterations- Saves time, labour and money	Expensive to set up, capital cost of computer and software
3D rotation and examination- Gives a better impression of a finished product	User needs to be trained
Ability to render in different materials- Design in more detail	Relies on electricity
Computer testing for quality control	Prone to virus, hardware breakdown
Ability to connect to CAM- Speed of production	
Send files via email- Saves time and money	

CAM	
ADVANTAGES	DISADVANTAGES
Allows quicker production	Expensive to set up, cost of equipment – machinery
Allows for a more detailed product	Puts people out of jobs (Ethics)
Files can be stored electronically	People need training
Greater accuracy and precision	Machinery needs maintenance
Much more safe- No human error	Relies on power



11. Social, Moral and Cultural issues

It is important that products are designed and made in a way that does not offend, exclude or insult potential consumers. A designer must ensure they translate language correctly to ensure what they are saying does not offend anyone but also to make sure they do not make their brand/company look silly.

Some patterns, shapes and imagery can be offensive in other cultures. An example of this is the use of images of people, Islamic traditions do not permit the use of these and instead replace artwork with geometric patterns, they believe the use of continuous pattern represents life. Different patterns and shapes represent different beliefs. In China black is associated with evil, dirt and bad luck. In China it is very unlikely that a garment made from black material would be bought and then worn to a wedding celebration or important party, whereas in the United Kingdom black dresses and suits are popular outfits at parties.

Fair trade

Fair trade is about establishing better prices, working conditions and terms of trade for farmers and workers.

Many supermarkets and department stores now stock fair trade goods and ingredients, such as tea, sugar, coffee, rice, dried fruit and chocolate. These products have been made with Fairtrade standards in mind.

12. Polymers

Thermo Polymers

Thermo polymers will soften when reheated. They are able to be remoulded into a new shape. This makes them suitable for recycling. The process of reheating and remoulding can be repeated many times. When reheated these plastics will try to return to their original shape. This is called plastic memory.

Thermo polymers include PET, HDPE, PVC, LDPE, PS, PP, ABS, Acrylic and TPE.

Thermo Setting Polymers

Thermo setting polymers can not be reheated and remoulded. This means they can not be recycled.

Thermo setting polymers include Polyester and Epoxy Resin.

Bio Polymers

Biopolymers are polymers that are produced by or derived from living organisms, such as plants and microbes, rather than from oil, the traditional source of polymers. The primary sources of biopolymers are renewable.

Starch and Cellulose are used to make Bio Polymers such as PLA.

Elastomers

Elastomers are polymers that have elasticity and therefore are flexible.

Rubber and Silicone are Elastomers.



13. Polymer Processes

You need to be able to sketch the diagram and explain the process step by step from memory.

Contact Adhesive: Joining Method (Workshop process)



- Contact adhesive can be used to join polymer sheets together. It is placed on both components and then pressed together. Surfaces must rough.
- Tensol cement joins acrylic and HIPS. Double sided tape can also join polymer sheets.

Polymer Welding: Joining Method (Workshop process)

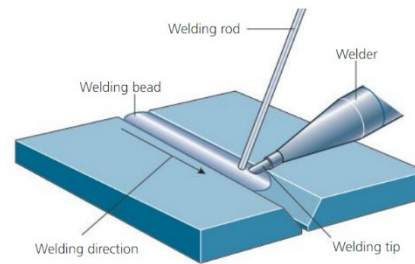

- Hot air is used to melt and fuse polymer components together

Drape Forming (Workshop process)

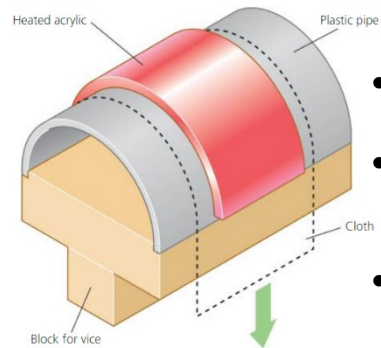

- Polymer is heated in an oven until soft/pliable.
- It is then draped over a former / jig and held in place.
- It hardens into shape

Press Moulding (Commercial process)

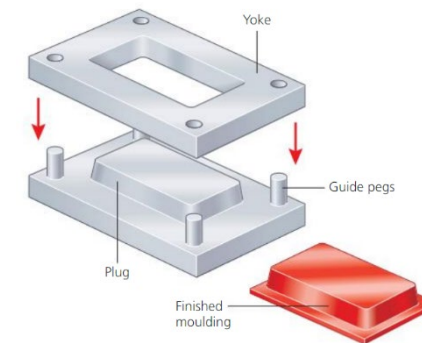

- Produces complex polymer shapes.
- Sheet polymer is heated until soft/pliable
- It is then placed in between the yoke and the plug
- The two-part formers pin the sheet polymer and pressure is placed on the yoke, forcing the polymer to take shape.
- Once cooled excess polymer is removed.



13. Polymer Processes

GRP/Carbon Fibre Moulding (Workshop/Commercial process)

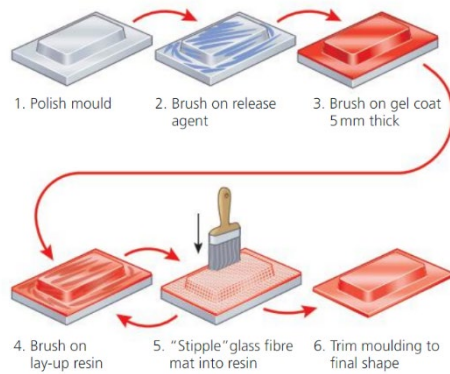

- Process used to mould Glass Reinforced Polymer (GRP) and Carbon Fibre.
- Used for boat hulls.
- Built up layer on layer.
- Fibres are layered between resin and built up to the required thickness over a mould.

Compression Moulding (Commercial process)

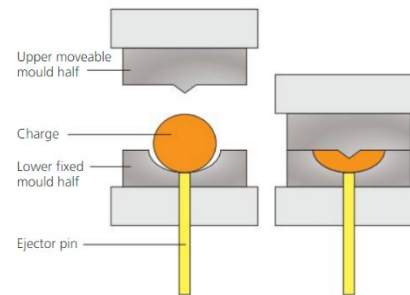

- Used to shape thermosetting plastics
- Polymer powder is heated and pressed into shape by a two-part mould.

Vacuum Forming (Workshop/Commercial process)

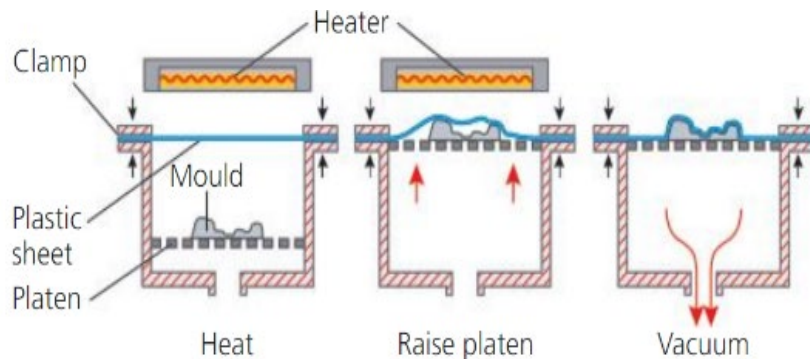

- Used to mould sheet HIPS using a mould/former.
- Polymer is heated until pliable and soft.
- The mould and former is raised into the polymer sheet
- Then a vacuum is created which pulls the sheet polymer onto the mould.
- Once cooled it is removed and excess material is cut off.



13. Polymer Processes

Rotational Moulding (Commercial process)

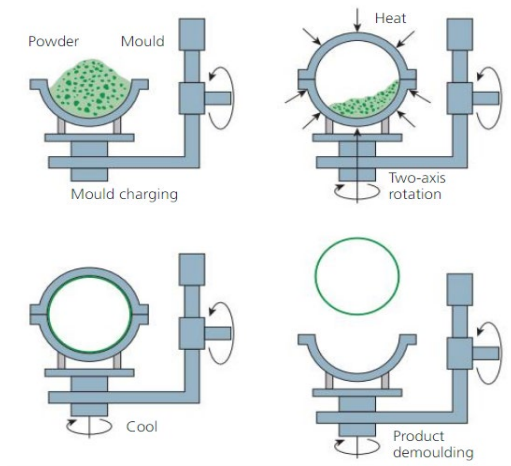

- A heated mould rotates.
- It contains a polymer paste or powder which is distributed evenly around the mould as it melts.
- The polymer covers all surfaces and is then cooled forming the shape.
- Used with hollow sit on children's toys, and slides.



Blow Moulding (Commercial process)

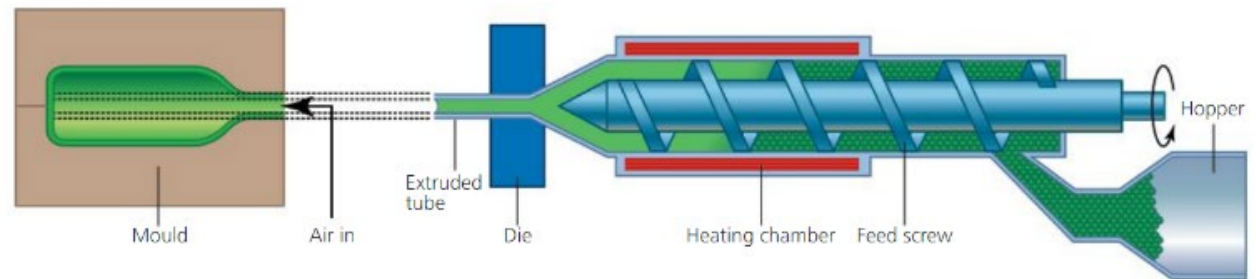

- A soft polymer tube (parison) is formed by feeding polymer pellets through a hopper, into a heating chamber and then through a die.
- The soft polymer tube (parison) is placed in the centre of a two-part mould.
- Air is blasted into the tube causing it to expand and press against the edges of the mould, it creates the shape of the mould.
- Blow moulding creates hollow shapes. Used to create bottles.



13. Polymer Processes

Extrusion (Commercial process)

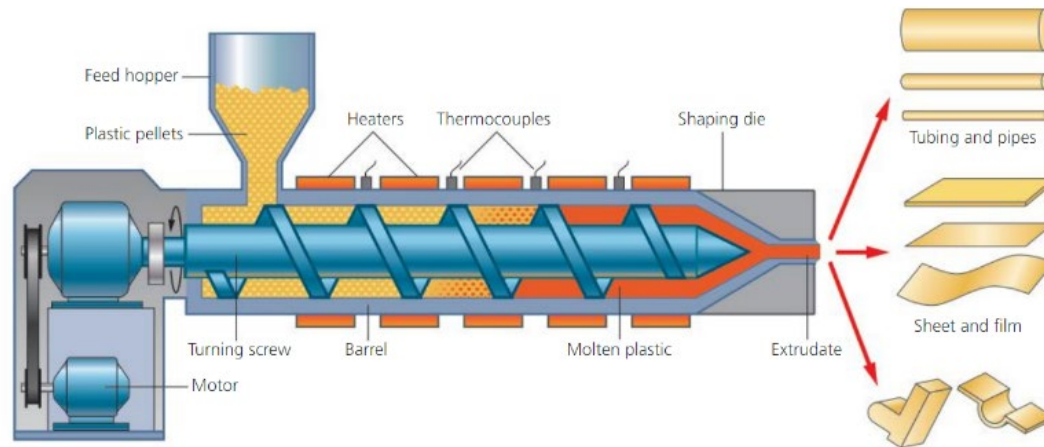

- Polymer pellets are fed through a hopper and heated until soft in a heating chamber.
- Molten (soft) polymer is then forced through a die to create a continuous shape before being cooled.
- The extruded polymer shape is then cut to length.
- Creates polymer pipes, sheets and tubes.

Injection Moulding (Commercial process)

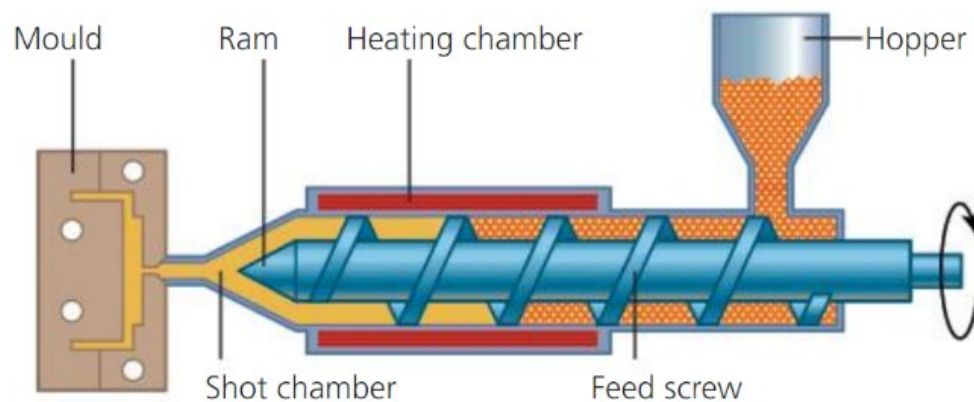

- Polymer pellets are fed through a hopper and heated until soft in a heating chamber.
- The soft polymer is then injected into a two part mould to create a solid polymer component/ shape.



14. Polymer Recycling Codes

1	2	3	4	5	6	7
PETE	HDPE	PVC	LDPE	PP	PS	OTHER
polyethylene terephthalate	high-density polyethylene	polyvinyl chloride	low-density polyethylene	polypropylene	polystyrene	other plastics, including acrylic, polycarbonate, polyactic fibers, nylon, fiberglass
soft drink bottles, mineral water, fruite juice container, cooking oil	milk jugs, cleaning agents, laundry detergents, bleaching agents, shampoo bottles, washing and shower soaps	trays for sweets, fruit, plastic packing (bubble foil) and food foils to wrap the foodstuff	crushed bottles, shopping bags, highly-resistant sacks and most of the wrappings	furniture, consumers, luggage, toys as well as bumpers, lining and external borders of the cars	toys, hard packing, refrigerator trays, cosmetic bags, costume jewellery, CD cases, vending cups	

15. Life cycle and disposing of Polymers

Polymers stay in the environment for a long time. Some can be recycled (Thermopolymers) but will take up to 450years to degrade naturally.

Some polymers a classed as bio-polymers and these have been made from plants and will biodegrade.

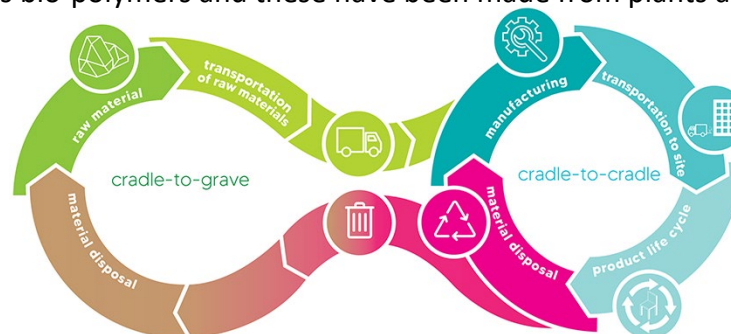

16. Where Polymers come from

Synthetic polymers are extracted and created from crude oil. Natural polymers are made from horns, hooves, tree resin.

Synthetic polymers extracted from crude oil are distilled to obtain chemicals like Ethene. These chemicals are further processed by using additives to give polymers their properties.

The following additives are used:

Plasticisers are added to improve the flow of the polymer for moulding. It also makes polymers flexible.

Pigments add colour to polymers.

Stabilisers help prevent damage from UV light.

Fillers bulk up polymer powder so less has to be used. It also improves strengths and resistance to impact.

Catalysts speed up the hardening time for polymers.

Antioxidants prevent oxidation.





17. Working with polymers

Polymers can be bought in the following forms:

Sheets, Granules, Rods, Tubes, Foam, Powder, Reels

Standard components manufactured from Polymers include:

Nuts and Bolts, Washers, Wall plugs, End caps, Plastic gear wheels.

Marking out Polymers:

Before manufacture you can mark out on polymers using fine line pens, a scribe or engraving on a laser cutter.

Cutting polymers

Polymers can be cut with a laser cutter, coping saw (hand tool), Scroll saw (mechanical fixed equipment).

Machining Polymers

Polymers can be shaped and machined manually using a lathe or milling machine. They can also be made directly from a CAD design using CNC machinery such as CNC lathes, milling machines and 3D printers. CNC stands for Computer Numerically Controlled. You can drill polymers using a pillar drill, hand drill or centre drill on a lathe.

Shaping polymers

Polymers can be heated and shaped using a heat strip (line bender), oven and former/mould/jig.





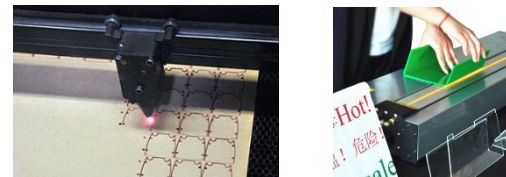





Computer Aided Engineering

Computer programs can be used to simulate and test how polymers would react, flow into moulds and perform when in use. Polymer products can be manufactured from CAD images by 3D printing (layer by layer)- this is known as rapid prototyping.





18. Thermo polymers

Recycling Code	Common name	Properties/working characteristics	Uses
	Polyethylene terephthalate (PET)	Clear, tough and shatter-resistant, PET has good moisture and gas barrier properties	Soft drink bottles, mineral water bottles, fruit juice containers and cooking oil bottles
	High-density polythene (HDPE)	Range of colours, hard, stiff, good chemical resistance, high impact	Milk crates, bottles, pipes, buckets, bowls
	Polyvinyl chloride (PVC)	Stiff, hard, tough, good chemical and weather resistance, uPVC (un-plasticized PVC) has strong resistance to chemicals and sunlight	Pipes, guttering, roofing sheets, window frames
	Low-density polythene (LDPE)	Range of colours, tough, flexible, good electrical insulator and chemical resistance	Washing-up liquid, detergent and squeeze bottles, bin liners, carrier bags
	Polypropylene (PP)	Hard and lightweight, good chemical resistance, can be sterilised, good impact, easily welded together, resistance to work fatigue	Medical equipment, syringes, crates, string, rope, chair shells, containers with integral (built-in) hinges, kitchenware
	Polystyrene (PS)	Range of colours, stiff, hard, lightweight, safe with food, good water resistance	Disposable plates, cups, fridge linings, model kits, food containers
	Expanded polystyrene (EPS)	Lightweight, absorbs shock, good sound and heat insulator	Sound and heat insulation, protective packaging
	Nylon	Hard, tough, resilient to wear, self-lubricating, resistant to chemicals and high temperatures	Gear wheels, bearings, curtain-rail fittings, clothing, combs, power-tool cases, hinges
	Acrylic	Stiff, hard, clear, durable outdoors, easily machined and polished, good range of colours, excellent impact resistance (glass substitute), does scratch easily	Illuminated signs, aircraft canopies, car rear-light clusters, baths, Perspex sheet
	Thermoplastic elastomers (TPE)	A combination of thermoplastics and elastomers. Flexible and tough. After stretching and bending they will return to close to their original shape	Watch straps, scuba diving masks, remote control buttons
	Acrylonitrile Butadiene Styrene (ABS)	Tough, high impact strength, lightweight, scratch-resistant, chemical resistance, excellent appearance and finish	Kitchenware, safety helmets, car parts, telephones, food mixers, toys



19. Thermo Setting polymers

Common name	Properties/working characteristics	Uses
Urea-formaldehyde	Stiff, hard, brittle, heat resistance, good electrical insulator, range of colours	White electrical fittings, domestic appliance parts, wood glue
Melamine-formaldehyde	Stiff, hard, strong, range of colours, scratch and stain resistance, odourless	Tableware, decorative laminates for work surfaces, electrical insulation
Phenol-formaldehyde	Stiff, hard, strong, heat resistance	Dark electrical fittings, saucepan and kettle handles
Epoxy resin	Good chemical and wear resistance, heat resistance to 250°C, electrical insulator	Adhesives such as Araldite® used to bond different materials such as wood, metal and porcelain
Polyester resin	Becomes tough when laminated with glass fibre, hard and strong but brittle without reinforcement	GRP boats, chair shells, car bodies

20. Elastomers

Elastomer	Properties/working characteristics	Uses
Silicone	Excellent heat and oil resistance	Flexible baking trays, bathroom sealant
Neoprene	Weather resistance, flame retardant	Wetsuits, knee and elbow pads
Butadiene rubber	Resistant to abrasion and cracking	Tyres, golf ball cores
Fluoroelastomer	Durable, chemical resistance	Apple Watch Sport straps



21. Metals

Metal is made by extracting metal ores from rocks in the Earth's crust by mining. The metal ore is then processed and refined. There are two main categories or types of metal:

- Ferrous metals – metals that contain iron. (Mild Steel)
- Non-ferrous metals – metals that do not contain iron. (Aluminium)

Ferrous metals contain iron and will corrode quickly and easily because of their iron content unless they are treated with a suitable surface coating such as paint, oil or wax. The majority of ferrous metals are also magnetic so will be attracted to a magnetic force.

Non-ferrous metals are much more resistant to corrosion and many are significantly better electrical conductors than ferrous metals. Non-ferrous metals are also more expensive than ferrous metals. Both types of metals are available in a wide variety of shapes and sizes.

An **alloy** is a mix of metals (Brass, Pewter).

22. Timbers

Woods are split into 3 categories: Manufactured timber, Hardwood and Softwood.

Hardwoods come from broad leafed deciduous trees such as oak, birch and teak. These grow slow so their use is less sustainable. They are used to make high quality furniture.

Softwoods come from evergreen trees such as pine and spruce. They grow quickly and are therefore more sustainable as they can be replaced more easily.

Manufactured timber is manmade and is using in sheet form, these include MDF and Plywood, hardboard and chipboard. They are created by gluing together layers, chips or sawdust and compressing them into the required shape/ size.

23. Textiles

Textiles are categorised as either a natural fibre, a synthetic fibre, blended fibres or woven fabrics.

Natural fibres are found in plants and animals. Examples are silk and cotton. These are sun to create yarns before making items.

Synthetic fibres are made from polymers and oil. They are used to create flame resistant fabrics and stronger, longer lasting fabrics. They will not biodegrade. Examples are nylon and polyester.

Blended fibres mix different textiles together to create better performing textiles (a bit like alloys). This happens for aesthetic reasons, strength or absorbency.

Woven fabrics are fabrics built up by weaving the material in opposite directions (under and over weave/ Warp and Weft) to create a strong material.

Non woven fabrics lack this strength and are created by bonding and pressing fibres together.



24. Papers and Boards

Paper is used by designers for sketching and presenting design ideas on. It is also used in marketing for posters, magazines, newspapers and labelling of products. It is measured in GSM (GRAMS PER SQUARE METRE), thicknesses range from 80gsm to 170 gsm. Above this is classes as board. Its thickness is measures in microns. Common paper types include layout paper, copier, cartridge paper, sugar paper. Paper can be given a gloss surface to make it more durable and look better.

Card is thicker and is measured up to 300gsm. It is easy to cut and fold. It is used for modelling and book covers. It can have matte, gloss or metallic finishes.

Cardboard is used for packaging, it is rigid, thicker than card and easy to cut, fold and print on.

Corrugated cardboard is strong, lightweight and is made up of three layers. It has two outer layers and a folded inner layer. This makes it stronger and more impact resistant. It is ideal for packaging fragile items.

Board sheets are thick, rigid mounting boards with a smooth surface. It is often used for picture frame mounts.

Foam board is made up of polystyrene sandwiched between two pieces of card.

Styrofoam is expanded polystyrene foam. It is blue and comes in a range of thicknesses. It is strong, light weight and a good insulator. It is good for modelling and creating moulds.

Corriflute has the same structure as corrugated cardboard but is made from lightweight plastic. It is used for 'for sale' signs, containers and packaging.

25. Composite Materials

Composite materials are man-made materials which combine two or more materials to make a new material with better properties and functions.

Carbon Fibre is an example of a composite that mixes Carbon Fibres and Plastic Resin, this makes the material incredibly strong but very lightweight.

Glass Reinforced Fibre mixes Glass Fibres and Plastic Resin, like Carbon Fibre this makes the material incredibly strong but very lightweight.

Concrete is a composite material.

Plywood and **MDF** are also classed as composite materials.

26. Why do we develop new materials?

New materials are developed to perform particular functions and have specific properties; they are intentionally developed, rather than being naturally occurring changes.

Many new materials are developed for specialised applications, though some eventually become available for general use. In the last ten years a range of smart materials has been produced for personal, domestic, medical, transportation and telecommunication applications.

We develop new materials to have improved properties. This allows materials to perform better and for products to perform better.



27. Smart Materials

Smart Materials sense conditions in their environment and respond to those conditions. They react to the environment they are in, this causes them to change. Most Smart materials will return to their original form when the environmental stimuli (what makes them change) is removed.

Thermochromic plastics or ink is a smart material, it changes colour when different temperatures are applied to it. It can be used on food containers, in fridges, as a thermometer and on baby products to ensure the contents or the environment is at the correct temperature. This material has been applied to clothes which change colour depending on the temperature of the person wearing it.

Photochromic materials change colour with changes in light intensity. Usually, they are colourless in the dark; when sunlight or ultraviolet radiation is applied the molecular structure of the material changes and it exhibits colour.

Phosphorescent Pigments can be applied to a variety of materials and their surfaces, they absorb energy and light during daylight hours and glow in the dark afterwards. They can be applied to warning signs and safety clothing to help during power cuts and at night.

Materials are being developed that **self-repair** themselves, for example a bridge could reinforce itself and seal cracks during an earthquake. Aerospace engineers are developing smart materials, which can automatically seal cracks in airplane wings. Cars are being designed with 'intelligent crumple zones', using smart materials to regain their original shape after an accident.

Optical fibres are fine glass tubes than can transmit information at high speeds in the form of light. It is most commonly used to provide high speed communication, it's only the thickness of a strand of hair. Technology like this has allowed business and manufacturers to develop the speed at which they can take a product from the design stages to the manufacture stage. The ability to now send CAD models and engineering drawings between businesses in seconds has dramatically improved the efficiency of product design. This has made distance between designers and factories no longer an issue and has meant communication is more reliable and therefore errors are reduced.

Shape Memory Materials are materials that will return to their original shape when heat or electricity is run through them. These can be alloys and polymers.

Polymorph are polymer pellets that can be shaped when heated in water. They are used to create prototypes for things like bike and crutch handles. When solidified polymorph is returned to warm water, it can be reshaped.



28. Motion/Movement

Linear - Moves in a straight line in one direction only (paper trimmer)



Rotary - Rotates around a central axis (Rotary Washing line)



Reciprocating - Moves back and forth or up and down along a straight line (Bike pump, sewing machine)



Oscillating - Moves back and forth along a curved line (Swing, clock pendulum)



29. Levers

A **lever** is a **mechanism** which needs three elements = Effort / Pivot (Fulcrum) / Load

There are 3 classes of levers, all 3 give different mechanical advantage.

Mechanical advantage is when a mechanism helps a human to make a task or moving a load easier.



Class one lever

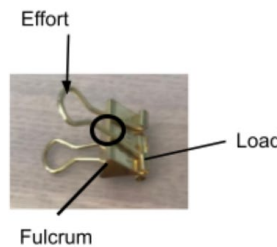
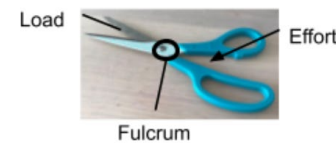

Class two lever

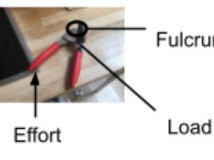
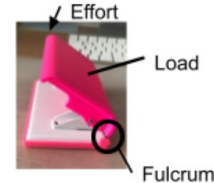

Class three lever

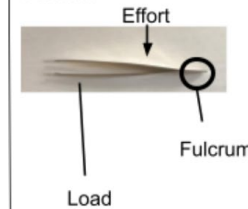
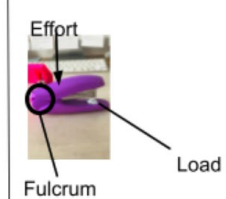



30. Gears

Gears are used to transfer motion in a range of directions within a mechanical object.

They can be used to change the direction of motion and also used to speed up or slow down motion.

Smaller gears rotate faster than larger gears.

Connecting gears rotate in opposite directions.

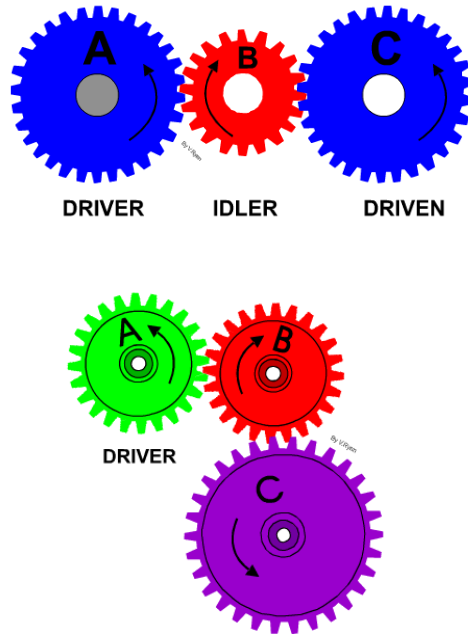

31. CAMS (Not Computer Aided Manufacture)

A **CAM** and a **follower** converts rotary motion into reciprocating motion.

The profile/shape of the CAM determines how the follower moves.

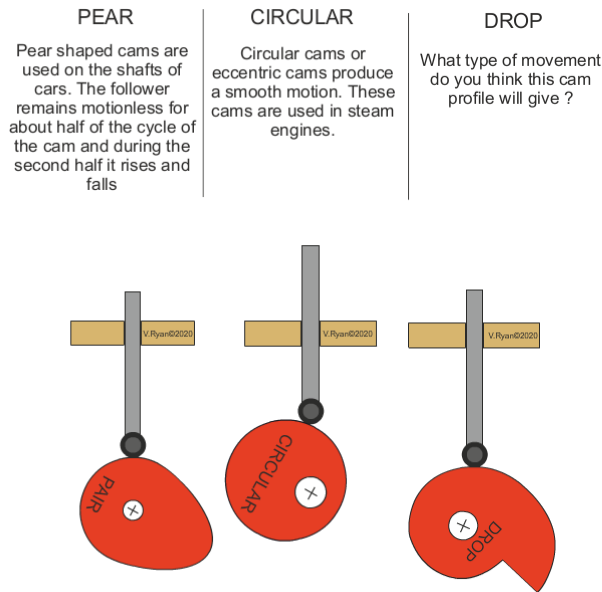

32. Electronic Components

Resistors control the flow of current within a circuit. They stop high rates of current damaging electronic components.



Capacitors Smooth the flow of current in an electrical circuit. They store and release energy.



PIC Chips are programmed to send signals. Between inputs and outputs. They control circuits.

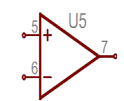

An **LDR** is a resistor which senses light. It allows current to run through it when it is dark.

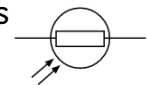

Speakers turn electrical signals into sound waves.

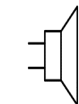

Switches are used to turn circuits on and off. They control when power enters a circuit and either complete or break the flow of current.

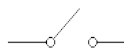

An **LED** is a type of bulb and emits light when current runs through it. LED stand for Light Emitting Diode.





33. Linkages

Linkages are used to transfer motion towards its required direction within a mechanical object.

Lever can also alter the type of motion.

Reverse motion linkage

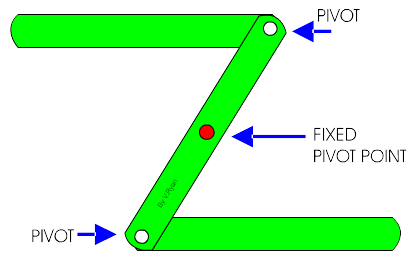

Crank and slider linkage

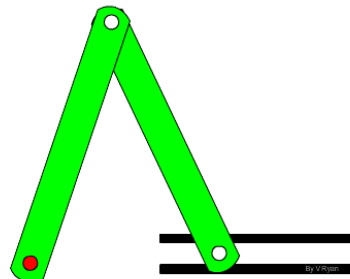

Bell crank linkage

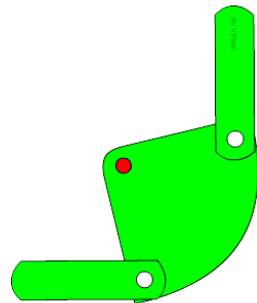

34. Pulleys and Belts

A pulley and belt drive can increase and decrease speed just like a gear train.

They transmit rotary motion. They can also be used for lifting loads to give mechanical advantage.

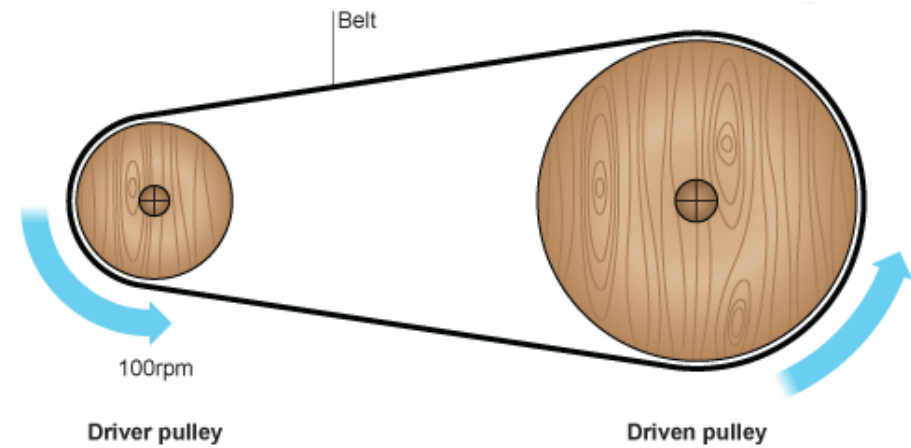
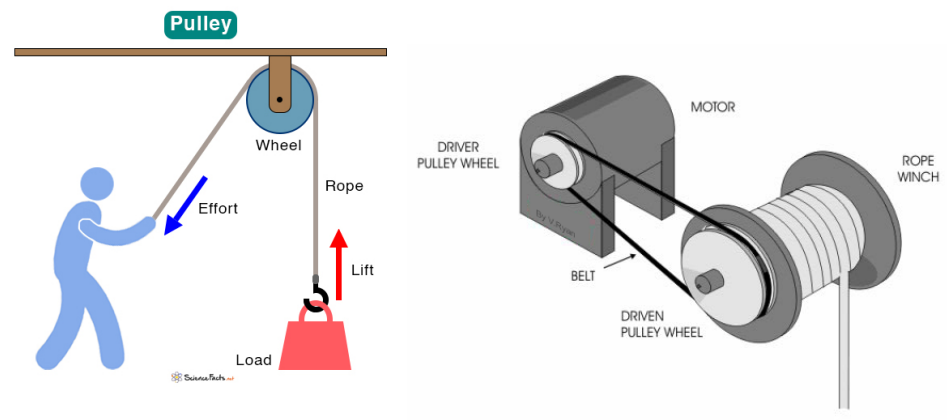

Page 24**35. Maths**

15% of the marks from the GCSE exam paper will be awarded for maths questions.

Express and convert simple fractions as decimals	$0.4 = \frac{2}{5}$ $0.5 = \frac{1}{2}$ $0.2 = \frac{1}{5}$ $0.25 = \frac{1}{4}$ $0.75 = \frac{3}{4}$
Calculation for speed	Distance divided by Time
Understanding percentages	The number of parts per hundred
Calculating percentages	80% of 55 : $\frac{55}{100} \times 80 = 44$
Calculating the ratio of quantities	50cm : 1.5m = 50:150 = 1:3
Calculating surface area	Rectangles- Height x Base Triangles- Height x Base /2 Circles- πr^2
Calculating Volume	Cuboid - Length x Base x Height
Calculating perimeter/Circumference	Rectangles/ Squares/ Triangles- Add all side lengths together Circles- $2\pi r$
Angles	<ul style="list-style-type: none"> • Sum of the angles at a point is 360 degrees • Sum of the angles on a line is 180 degrees • Isosceles Triangle- 2x equal angles and x1 acute. Sum = 180 degrees • Equilateral Triangle- 3x 60 degree angles. Sum = 180 degrees • Right angle Triangle- 1x 90 degree angles and x2 acute. Sum = 180 degrees
Scaling Drawings	1:1 = Same size (do not change dimensions) 1:2 = Half size (divide dimensions by 2) 2:1= Twice as big (times dimensions by 2)
Averages	Mean= add up all the data and divide by the number of units Range= Difference from the smallest to the largest Median= The middle



Support with NEA (Coursework)



36. Iterate, Develop, Create

All designers develop and iterate (change and improve) ideas in order to find the best solutions to everyday problems and user needs.

Create a page of different design developments for everyday products. Your design pages must have at least 5 designs on and your solutions must be for different primary users who would use the items in different places.

Visit this link to a sketch-a-day YouTube channel. Pick a video tutorial and develop your drawing skills by following the instructions and demos.

https://www.youtube.com/channel/UCBtSgEZk914z5InEs_U2J3w

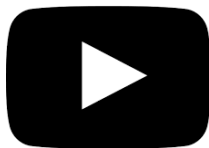

37. Product Analysis

A good product analysis evaluates products highlighting their strengths and weaknesses. It tells us what features are worth developing and what features should not be. It is an essential part of market research.

A strong product analysis will answer the following questions.

What are the main purposes of the design? Form, Function or both?

The main purpose of this clock design is to ... I think this because...

Who is the primary user of the product?

I think the primary users are....

Why may it be successful for the user?

I think this design would be successful because...

Why may it be unsuccessful for the user?

I think this design would be unsuccessful because...

What materials have been used and why are these suitable?

The materials chosen are..... their properties are suitable for this product because....

What changes would you make to develop the design to improve it? Why would I make them?

I would develop this design further by... I would do this because...



38. Annotating design ideas

Strong annotation will fully explain your design ideas and design choices. Your annotation should answer the following things.

- **What are the design features and why have you chosen them?**
- **How does your idea function?**
- **Why is it suitable for the primary user?**
- **How does it solve the problem identified in your brief?**
- **What specific materials have you chosen and why are their properties suitable for the function of your idea?**
- **What are the strengths of your idea?**
- **What are the weaknesses of your idea?**
- **How many of the primary user and stakeholder needs does the idea meet?**
- **How could you improve the design idea further?**
- **What feedback do others give you about the idea?**

Your annotation should be around your idea, bold and must not cover any of the design. Do not draw arrows over your idea.

39. Interviewing Primary Users and Stakeholders.

We interview primary users and stakeholders as part of our market research. This can be face to face, online or over the phone. We ask them questions and use the answers to create primary user and stake holder needs.

Types of questions they should be asked.

- **Do you have any struggles when carrying out tasks described in my design brief.**
- **What current solutions do you have for these problems?**
- **What products do you currently use that help you in this area?**
- **What future solutions would help these issues?**

40. Primary User and Stake Holder Needs

This is a list of requirements that the products you design should meet. You have two lists, one for the primary user needs and one for the stake holder needs. We use these lists as a checklist as we are designing. Our designs should meet as many of the needs as possible in order for it to be successful.

Each primary user and stake holder need must start with: The solution should must....

Example: The solution must be easy to carry around.



41. Primary Users and Stakeholder interview example.

Primary user survey: 1

- Q1. What kind of medication organiser do you own at the moment?
A. Pre packed at chemist- blister pack.
- Q2. What issues do you get with remembering when to take medication?
A. Need to put alarm on to remind when to take.
- Q3. What kind of product would be helpful with organising and remembering to take a tablet?
A. Something with alarm system on/ timer. Easy access to tablets pets often fiddly for older people.
- Q4. On average how many tablets do you take a day?
A. 8 per day.
- Q5. What kind of problems do you have with your medication organiser at the moment?
A. Sometimes trying to get small tablets out of pots, also opening of box.
- Q6. Who are you caring for or would this product help you personally?
A. Parent.
- Q7. Would you prefer a daily, weekly, monthly or yearly organiser?
A. Weekly.
- Q8. Would it be helpful to have a timer attached to the organiser?
A. Yes.
- Q9. Would it be helpful; to have the organiser attached to a water bottle?
A. Possibly, depending on style and added weigh.
 Maybe it could be attached but able to detach?
- Q10. What would be a perfect size for the organiser?
A. For elderly, I think it needs to be big enough for them to access the tablets, often their fingers/ hands can struggle due to their conditions is arthritis.

Primary User survey: 2

- Q1. What kind of medication organiser do you own at the moment?
A. I do not own one as I just use the packets.
- Q2. What issues do you get with remembering when to take medication?
A. At the moment I have a timer on my phone.
- Q3. What kind of product would be helpful with organising and remembering to take a tablets?
A. Something light weight and compact.
- Q4. On average how many tablets do you take a day?
A. One or two.
- Q5. What kind of problems do you have with your medication organiser at the moment?
A. Things can get mixed up and there is a lot of packaging.
- Q6. Who are you caring for or would this product help you personally?
A. This would be for myself.
- Q7. Would you prefer a daily, weekly, monthly or yearly organiser?
A. Weekly.
- Q8. Would it be helpful to have a timer attached to the organiser?
A. Yes so I would not have to have it on my phone.
- Q9. Would it be helpful to have the organiser attached to a water bottle?
A. Yes so that it can be carried around.
- Q10. What would be the perfect size for the organiser?
A. Average bottle size made out of light weight material so that it is not heavy in my bag.

Stake holder survey: 1

Doctor:

- Q1. What is the average age of a patient that you give medication to?
A. 75 years.
- Q2. How could I make a product to help organise medication for you?
A. Days and times written, a list of medication with colour description and a detailed letter about the days that patients is on.
- Q3. How could I make a product to help organise medication for the user?
A. Colour coded, alarm and easy to open and close.
- Q4. How big or small would the pill holder need to be?
A. 3 inches minimum.
- Q5. Do you get any problems with patients remembering to take medication if so how often?
A. Yes dementia. After surgery, sedation if patients do not understand the importance taking these drugs.

Summary:

I have asked two primary users one from my nan and the other from somebody from my mums work. I have also got a questionnaire from a doctor I was working with for a week. From asking the questions that I thought would be helpful I have learnt things that I need to consider and avoid.

Things to consider:

Having an alarm, easy access, weekly organiser, light weight, compact (3 inch min) and easy to understand (colour coded).

Things to avoid:

Lots of packaging and hard to get out of pots, making it to heavy or big.



42. Primary User Needs examples

Context – primary user needs and stake holder needs.

Primary user needs:

- **The primary user needs the solution to be easy to use.** the main primary user for this solution would be elderly and therefore if you had a complex product it could become complicated. So the elderly user would need to be able to easily use this product without getting confused.
- **The primary user needs the solution to be lightweight.** the main primary user for this solution would be elderly and therefore if you had a heavy product that is not easy to move around the elderly user could trip and fall and majorly or fatally hurt themselves. My stakeholder said that trips and falls are the main accident that happen in care homes per year. In conclusion the elderly user would need to be able to move or pick up the solution without it being heavy enough to majorly hurt them.
- **The primary user needs the solution to be easy to store.** The main primary user for this solution would be elderly and therefore if the solution is not able to be stored and is constantly in the way the elderly user could hurt themselves on it. Whether the injury is tripping or bumping into it, it could cause a major fatality as elderly people are a bit more fragile. My stakeholder said that when the elderly cut their heads its usually from walking into high up products or not seeing something that they are about to walk into. So, it would be safer if the elderly user had nothing to trip or bump into because it was safely stored away.
- **The primary user needs the solution to be safe.** The main primary user for this solution would be elderly and therefore if the solution is dangerous it could cause a serious accident or even death. My stakeholder told me that many elderly people have impaired vision so if something sharp or easily smashed into shards was around 9/10 times the elderly user would hurt themselves on it. In conclusion the elderly user would need a safe and age appropriate solution.
- **The primary user needs the solution to be multi functional.** The main primary user for this solution would be elderly and therefore if the elderly user needs more than one thing at the time and they are all in different spaces, the user could become quickly disorientated. My stakeholder stated that if an elderly user needed multiple things at once and could not find them, it would take forever to become sorted and could miss important events. So, if the solution was multi functional it would be beneficial and time efficient.
- **The primary user needs the solution to support them in table based activities.** The main primary user for this solution would be elderly and therefore if they are sat at a table doing activity they would need more space to organise them self and have everything they need close by. My stakeholder told me a story of one of the elderly ladies he was working with who was doing a puzzle at a small table, she had a cup of coffee on the Table too but as she moved the puzzle she knocked off her hot cup and badly burnt herself. In conclusion, a small table could become dangerous to an elderly user and a solution that could declutter or increase the surface area of a table would be ideal.
- **The primary user would prefer the solution to be adjustable.** The main primary user for this solution would be elderly and therefore if the product was in a fixed position it could be difficult for the elderly user to use and could become insufficient for their needs. My stakeholder told me that elderly people can become easily stressed and annoyed with products if they are not sufficient to their needs and cause them unnecessary strife. In conclusion, it would be beneficial if the product was able to move to the satisfaction of the elderly user.
- **The primary user would prefer the solution to be small.** The main primary user for this solution would be elderly and therefore if you have a huge solution it could be easy to harm themselves on and hard to maintain which could become expensive. If the solution was small then the elderly user would have a easier and more enjoyable time working the product without endangering themselves or their bank account.

Bethanie Scruton



43. Initial Ideas

We must have 6-8 initial ideas that are all very different. These must meet the primary user and stake holder needs. These ideas need to be fully annotated.

Primary user Feedback:

- I like this product because it enables me to read whilst in bed whilst having a light to help me see and its adjustable to make me comfortable using it
- I believe it could be improved by adding a cushioned surface area on the bottom of the product to maximize the comfort and also prevent me from hurting my knees.

Stakeholder Feedback:

- I like this product because it keeps the resident content whilst I am doing my job around the apartment.

Primary user Feedback:

- I like this product because it helps me reach far away objects without injuring myself and also it comfortable and easy for my hands to grip.
- I believe this product could be improved by maximising strength, security and length of the pole to make sure it can hold heavy things.

Stakeholder feedback:

- I like this product because it means I don't have to run around to get everything the resident needs because they can reach it by themselves making my job easier.

Primary user Feedback:

- I like this product because it stops me from hurting myself on sharp corners and protects me from external harm.
- I believe this product could be improved by having a larger surface area.

stakeholder feedback:

- I like this products because it makes me able to do other things without worrying about my resident hurting themselves

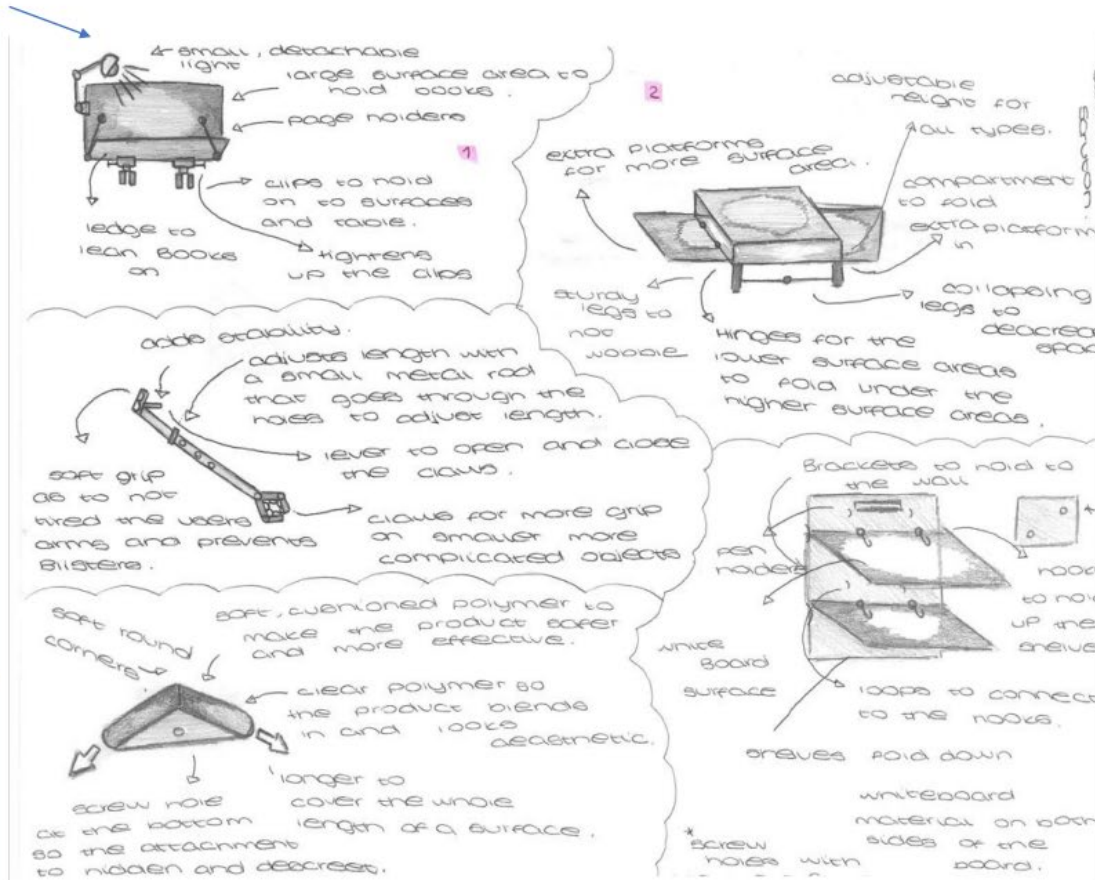

Primary user Feedback:

- I like this product because it gives me a surface area where I can do multiple activities.
- I believe this product could be improved by making it easier to open/ close and put away.

Stake holder feedback:

- I like this product because it allows my residents to complete activities on their own without help and have plenty of space.

Primary user feedback:

- I like this product because it can give me space to hold my things and can be folded up so that I cant hurt myself on it when its not being used.
- I believe it could be improved by making the product stronger to hold a variety of items which could be light or heavy.

Stake holder feedback:

- I like this product because it doesn't take up floor space for storage which could be beneficial to my resident moving around.



44. Design iterations and developments

All design ideas need to be developed and improved based on feedback and improving how it meets user needs. Good design iteration will explore a range of possible solutions for a design idea. Each suggestion is accompanied by a sketch and clear annotation.

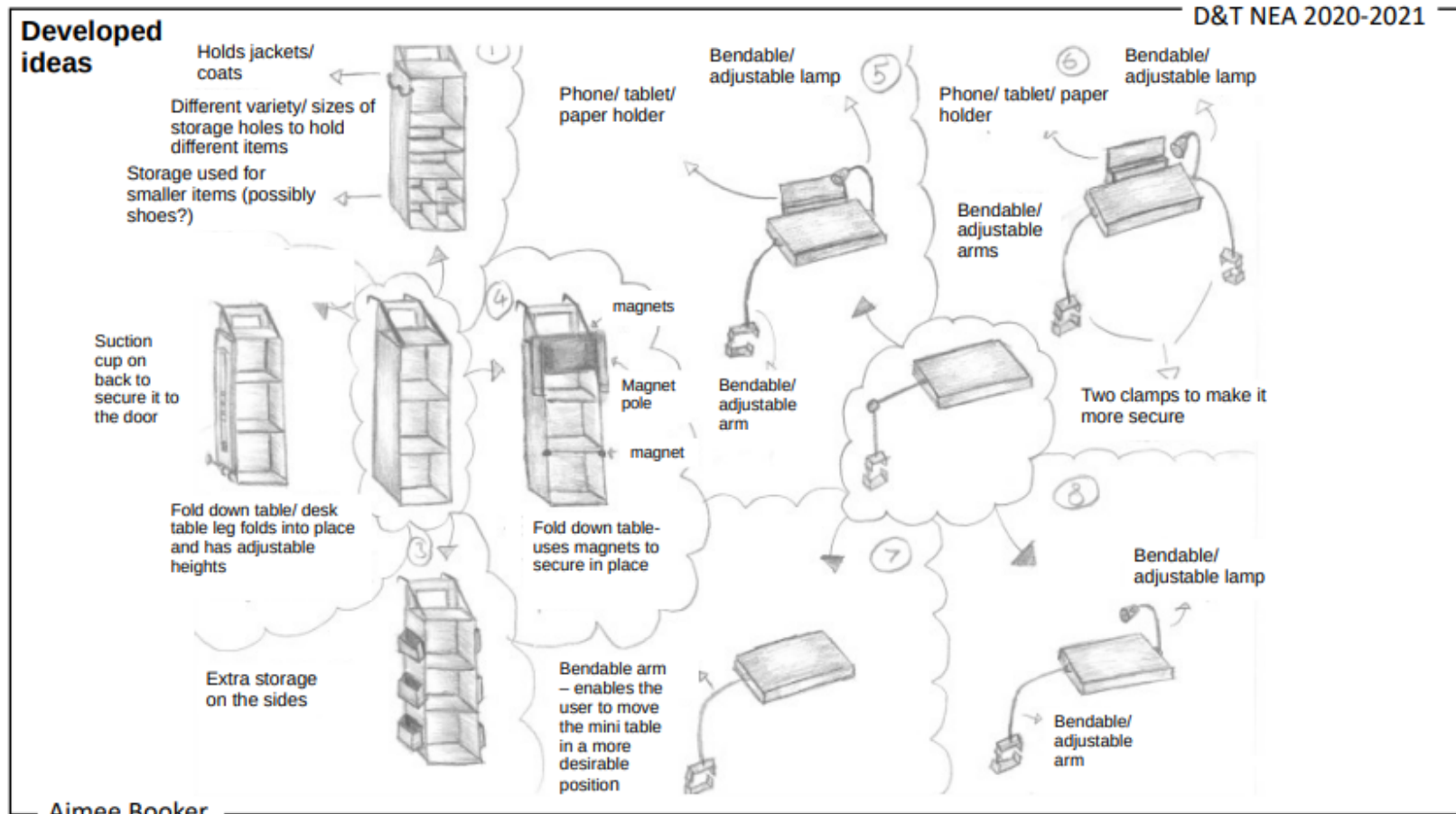



45. Technical Specifications

Technical specifications give a third party enough information to be able to manufacture your product. They must be able to manufacture it both in the school workshop and also commercially.

You must have a list of materials for each component. An explanation of how each component will be made both for the prototype and commercially and a Technical Orthographic drawing.

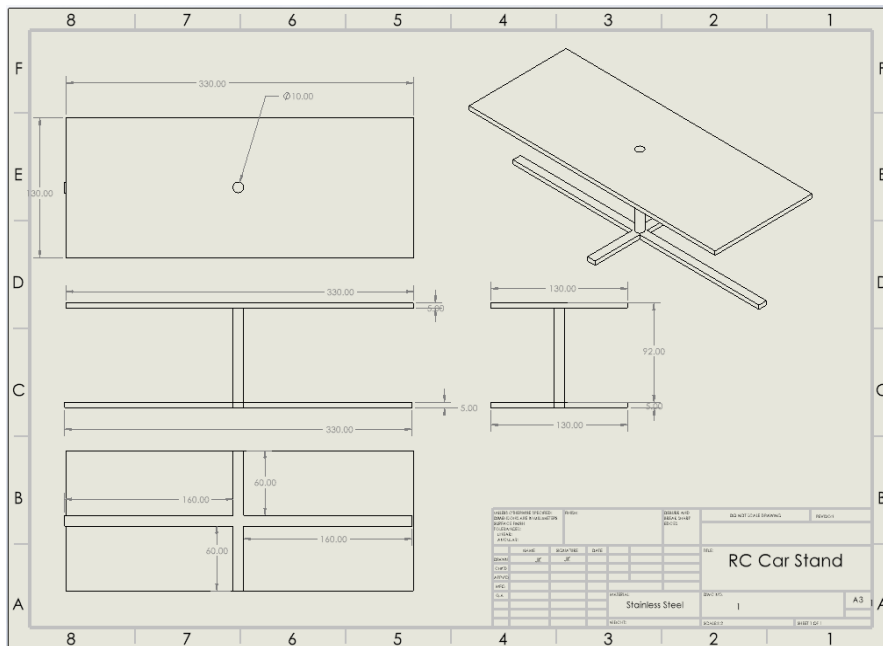

46. Evaluating ideas.

We evaluate our work at the design stage, development stage and final outcome stage.

We compare our ideas and our outcomes against the primary user needs and we say what's good, what could be improved and how we could improve it.

We get feedback from primary users and stakeholders throughout the process and we use these along with our own opinions to decide how our work can be improved.

PUN	key dividers	swiss army	magnetic	shuter box	cylinder tube	briefcase	key wheel	fold out	key belt	honeycombe/hive
accessibility	5	3	4	5	4	4	5	3	3	5
security	0	1	3	5	3	3	1	3	2	3
easy to use	5	5	4	5	3	3	5	3	4	4
easy to identify key	3	4	5	5	3	4	4	3	3	2
mobility	5	5	1	2	4	4	3	4	5	3
space saving	3	4	3	4	3	4	4	3	4	4
practicality	0	5	3	4	3	3	3	3	4	3
score: /35	21	27	23	30	23	25	25	22	25	24

Feedback:

- Easy to use and understand
- Lightweight good for moving
- Being able to slot them together is neat and really useful for storing
- The overall flexibility of the product is extremely helpful
- Sometimes its hard to slot them together

Strengths for the user:

- Lightweight
 - Simple to use and understand
 - Can be identified easily
 - Interchangeable like Lego
 - Aesthetically pleasing
 - Easily adapted for an environment/ certain job
- Weaknesses for the user:
- Keys could potentially be knocked out by accident



47. Final prototype evaluation.

Final design evaluation:

User feedback:

Positives:

My user liked that fact that the inside parts were made out acrylic so they could be washed if any tablets that are filled with liquid exploded. They also like that my product was made out of wood as it is sustainable. Another thing was that there was no writing but instead symbols that implied what time they needed to take those tablets as it can be confusing for both carer and the person taking them. Finally they liked that it was very easy to open and see the tablets as often tablets come in a sealable pack that is hard for the elderly to peel.

Things to improve:

Some things they said I could improve on was that my lid had no latch meaning that if they were to take it out they might loose some tablets. Also they would have preferred it to be smaller so that it can be transported and if someone wanted it for younger children they would be able to hole it easier.

Strengths:

My strengths are that it is easy to see the what time of day they are supposed take there medication. The second is that I have made separate parts that can be easily removed and washed. Another is that it is made out of ply wood meaning that is very sustainable.

Weaknesses:

I could have made it a little smaller so that it is easier for the elderly to hold. I also would make it more durable so that if they dropped the product there is no chance of it breaking.

Modifications:

From my user feedback I have decided that if I was to make it again I would make it shallower so that it would be easier to fit in to a bag. Another thing I would do is add a latch to the lid so that nothing could fall out if it was tipped upside down in a bag. Also I could thing about other ways that I could attach the lid such as having it slide in and out so it is more compact and aesthetically pleasing. I could add a timer so that it would buss to tell you when a tablet needs to be taken or it could connect to an app on your phone. Finally I could vacuum form the inside compartments to optimise my product

Does it meet my stake holder needs?

- 1. The product must be cost efficient.** It need to be cost efficient so that the manufacturer can make a cheep but durable product. Also as we want to be marketing it as an affordable product.
- 2. The product must be compact.** It need to be compact so that they can store lots of them to sell. Also so that it will appeal to the consumer.
- 3. The product needs to be easy to understand.** The product needs to be easy to understand so that the primary users can understand what it is used for on display so that the stake holder dose not need to explain. Also so that if the user has a new carer they will automatically understand when the tablets need to be taken so that the elderly person does not miss any tablets.
- 4. The product needs to be durable and sustainable.** It needs to be durable so that if one gets dropped in the shop it will not smash and break and we will not be wasting money in production. It also needs to be sustainable so that we can make a lower impact on the environment which could also be a marketing point.

Shallower:



Latch:



Sliding lid:



Timer:



Conclusion- is my product viable:

I feel as though my product could be marketable if I had made some modifications. This is due to the fact that from my product research I found that my user really liked my product but they wanted some adjustments. If I made these such as making it shallower it would mean that I have made a product that my user and stake hold would want. Also if I was to vacuum form instead of laser cut the compartments it would be optimising my product on a mass production. Finally my mould was made out of wood but if I was to make it on mass production I would make the mould more durable my making it out of aluminium.



48. Production Log

When manufacturing your prototype you must keep a log of everything you do. This includes what tools you used for each component, What you did, Quality Control checks you made and Health and Safety considerations you made.

Production plan:

Process:	Equipment:	Estimated time:	Safety & quality control:	Modifications made:
Marking out my wood (MDF) for my male and female mould.	I will need my MDF, a compass, a ruler and my pencil.	This will take around 30mins as I need to make sure I get the exact measurements I need.		Now my markings would be made on to the wood so they are ready to cut.
Cutting out my mould.	I will use a band saw as I will be able to get around the curves easily.	This will take me about 1hours as I need to cut out two moulds.	I will need to wear goggles, tie my hair up, wear an apron and stand up.	Now my wood would be cut out so we can glue it and wrap my ply wood around it.
Sanding down the mould.	I will need a belt sander, a file and a vice.	This will take me about 30mins as I need to make sure the two moulds are the same size.	I will need to wear goggles, tie my hair up, wear an apron and stand up.	Now my two moulds will be equal to one another and ready to glue.
Glue both layers of mould together.	I will need some PVA glue, a brush and a vice/clamps.	This will take about 15mins and the I will leave in vice/clamps overnight to dry.	I will need to wear an apron so that I do not get glue on my cloths.	Now my mould is the right size so that it is the ply wood will fit.
Ply wood cutting.	I will need a craft knife, a cutting mat, a safety ruler and a pencil.	This will take me about 1 hour as I need to cut 5 x 4mm plywood.	I need to tie my hair up, wear an apron and keep my finger inside the safety ruler.	Now I will have 5 strips that are going to curve around my mould.
Ply wood bending.	I will need PVA glue, a clamp and a brush.	This will take 30mins and then I will leave this in the vice overnight to dry.	I will need to wear an apron and get glue on my cloths.	
Sanding down the ply wood.	I will need a belt sander, a file and some glass paper.	This will take me about 30mins as I need there to be no glue around the edges.	I will need to wear goggles and have an apron.	
Design top and bottom.	I will need 2D design on a computer.	This will take about 1hour as I need to make sure that the lid will not hang over the edge.		
Laser cutting my lid and bottom.	I will need a laser cutter and a computer.	This will take about 15mins.	I will need to make sure the extractor fan is on.	
Glue on bottom.	I will need PVA glue, a clamp and a brush.	This will take about 30mins and then I will leave this to dry overnight.	I will need to wear an apron and get glue on my cloths.	
Vacuum form.	I will need a vacuum former, my material and my product.	This will take about 15mins.	I will only need to wear a	
Add hinges to lid.	I will need a screw driver and some screws.	This will take about 15mins.		

Production diary:

This is my female and male mould that I cut out.

This was me cutting out my strips of ply wood with a craft knife.

This was my strips of ply wood wrapped around my mould held by a clamp.

This was my design for the lid, base and inside separators on 2D design.

This is me cutting out my mould on the band saw and then sanding down.

This was my parts that I had drew up getting cut out on the laser cutter in ply wood. I then glued these together.

This was my design from my inside compartments that I changed from my plan. I then laser cut and glued the layers together.

This was me waxing my wood so that it will keep clean.

This is my final product with the separate compartment inside, the lid nailed on and with the bottom glued on.



49. Glossary of key language

Circular economy

A circular economy is an alternative to a traditional linear economy (make, use, dispose) in which we keep resources in use for as long as possible, extract the maximum value from them whilst in use, then recover and regenerate products and materials at the end of each service life. It aims to keep products, components and materials at their highest utility and value at all times.

Context

Circumstances that form a setting, surroundings, people, places, events that all form a setting for us to design within.

Creativity

Creativity is a phenomenon whereby something new and valuable is formed. The ability to transcend traditional ideas, rules, patterns, relationships, or the like; to create meaningful new ideas, forms, methods, interpretations, etc. originality, progressiveness, or imagination.

Critique

Critique is a method of disciplined, systematic analysis of a written or oral discourse. Although critique is commonly understood as fault finding and negative judgment, it can also involve merit recognition, and in the philosophical tradition it also means a methodical practice of doubt. It is detailed evaluation.

Design optimisation

Product design and development requires that engineers consider trade-offs between product attributes in the areas of cost, weight, manufacturability, quality and performance. It is about determining how to arrive at the best overall design, making the right compromises and not sacrificing critical attributes like safety.

Design solution

A design solution is a generic term that can be used to outline any existing products or systems, or any design development that is offered as an answer to needs, wants and requirements. This can be a fully drawn up solution, a prototype or an existing product.

Digital design

Digital design is the use of computers, graphics tablets and other electronic devices to create graphics and designs for the web, television, print and portable electronic devices. Digital designers use creativity and computer skills to design visuals associated with electronic technology.

Disruptive technology

Disruptive technology is a new emerging technology that unexpectedly displaces an established one. Recent examples of disruptive technologies include smart phones and e-commerce retailing.



50. Glossary of key language

Disassembly

To disconnect the pieces of (something), to take things apart into smaller pieces. Used within Design and Technology to analyse and test products.

Ecological footprint

Ecological footprint is a measure human impact through supply and demand on nature. It represents the productive area required to provide renewable resources that humanity is using and to absorb its waste.

Enterprise

Relating to a progressive approach that demonstrates initiative, resourcefulness and willingness to undertake new and challenging projects.

Fixation

The state of being unable to stop thinking about something, or an unnaturally strong interest in something. We talk about this in terms of design fixation, i.e. being fixated with an idea.

Global sustainable development

Sustainable development relates to the principle of sustaining finite resources that are necessary to provide for the needs of future generations of life on the planet.

Innovation

Innovation in the context of this qualification refers to learners considering new methods or ideas to improve and refine their design solutions and meet the needs of their intended market and/or primary user.

Iterative design

Iterative design is a design methodology based on a cyclic process of prototyping, testing, analysing and refining a product or process. Within the context of this specification we refine these processes to explore/create/evaluate. In iterative design, interaction with the product or system is used as a form of investigation for informing and evolving a project. Based on the results of testing the most recent iteration of a design, changes and refinements are made.

Just-in-time (JIT)

Just-in-time (JIT) manufacturing, also known as just-in-time production or the Toyota production system (TPS), is a methodology aimed primarily at reducing flow times within production as well as response times from suppliers and to customers. A strategy companies employ to increase efficiency and decrease waste by receiving goods only as they are needed in the production process, thereby reducing inventory costs.



51. Glossary of key language

Lean manufacturing

Lean manufacturing or lean production, often simply “lean”, is a systematic method for the elimination of waste within a manufacturing system.

Lifecycle assessment (LCA)

Lifecycle assessment (LCA), also known as lifecycle analysis, eco-balance, and cradle-to-grave analysis is a technique to assess environmental impacts associated with all the stages of a product’s life from cradle-to-grave (from raw material extraction through materials processing, manufacture, distribution, use during its life, repair and maintenance and end of life disposal or recycling).

Primary user

The primary user is that person or group of people that are intended to practically use a product or system in their lives. Many products may have primary users that use the same product in different ways or with different purposes.

Prototype

In the context of this qualification, the term ‘prototype’ refers to a functioning design outcome. A final prototype could be a highly finished product, made as proof of concept prior to manufacture, or working scale models of a system where a full-size product would be impractical.

Social footprint

Social footprint is linked to the carbon footprint, implying that all human actions leave a trace and sometimes our lifestyle choices have negative consequences on the environment.

Solution

A solution is a way to solve a problem or resolve a bad situation.

Stakeholder

A stakeholder is a person, group or organisation with an interest in a project; for example, parents/schools when designing products for children; the manufacturer or retailer that has an interest in a product; a regulator who needs to ensure products meet required regulations within a jurisdiction; when acting as a designer, the stakeholder that you are working for would be defined as a client.

Upcycling

Upcycling, also known as creative reuse, is the process of transforming by-products, waste materials, useless and/or unwanted products into new materials or products of better quality or for better environmental value.

User-centred design

User-centred design (UCD) is a framework of processes (not restricted to interfaces or technologies) in which the needs, wants and limitations of end users of a product, service or process are given extensive attention at the stage of the design process.